

# Technical data sheet



## Product features

### Fry-top griddle plate 40x51 electric chromed smooth without cabinet 400 V

<b>Model</b>	<b>SAP Code</b>	00012427
--------------	-----------------	----------



- Top type: Smooth
- Griddle dimensions [mm x mm]: 400 x 510
- Griddle thickness [mm]: 12.00
- Worktop material: Chrome plated steel
- Container for liquid fat: Yes
- Maximum device temperature [°C]: 300
- Surface finish: polished chrome 0.03 mm
- Removable rim: Yes

<b>SAP Code</b>	00012427	<b>Power electric [kW]</b>	4.500
<b>Net Width [mm]</b>	400	<b>Loading</b>	400 V / 3N - 50 Hz
<b>Net Depth [mm]</b>	700	<b>Griddle dimensions [mm x mm]</b>	400 x 510
<b>Net Height [mm]</b>	330	<b>Top type</b>	Smooth
<b>Net Weight [kg]</b>	36.00		

# Technical data sheet



Technical drawing

Fry-top griddle plate 40x51 electric chromed smooth without cabinet 400 V

Model

SAP Code

00012427

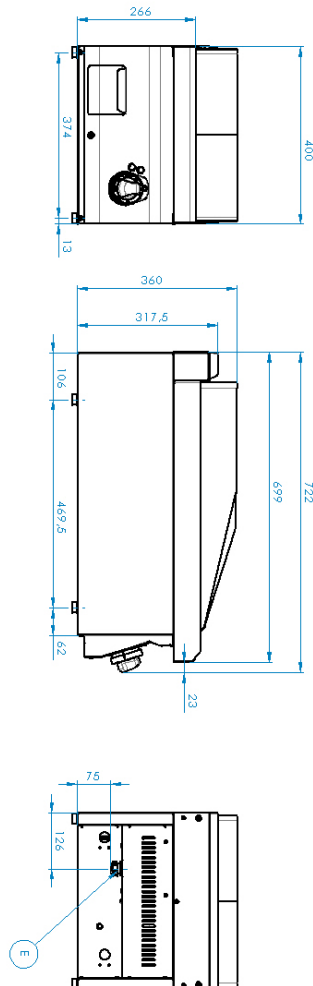

# Technical data sheet



## Product benefits

### Fry-top griddle plate 40x51 electric chromed smooth without cabinet 400 V

Model

SAP Code

00012427

1

#### All-stainless design

- long life
- corrosion resistance of the top plate material
  - savings on service interventions
  - easier and faster operation

2

#### Degree of protection of the control elements IPX4

- maintenance-free system
- resistance to splash water
- long life
  - savings on service interventions
  - easy cleaning and maintenance of equipment

3

#### Outlet for waste liquids

- ensures that oil drips into the socket
  - easy maintenance
  - easy cleaning

4

#### High detachable hem

- better hygienic conditions
- preventing grease from splashing onto ancillary equipment
  - easy maintenance
  - easy cleaning

5

#### Smooth plate made of chrome-plated steel

- the product bakes less and is easier to clean
- a good warming of the meat with a groove
  - time-saving for food preparation
  - no reheating and long cooking times

6

#### Cooking unit for use on a table or on a base

- variable use
- the possibility of placement in smaller spaces
  - easy handling
  - cost savings on substructure

# Technical data sheet



## Technical parameters

### Fry-top griddle plate 40x51 electric chromed smooth without cabinet 400 V

<b>Model</b>	<b>SAP Code</b>	00012427
--------------	-----------------	----------

**1. SAP Code:**

00012427

**2. Net Width [mm]:**

400

**3. Net Depth [mm]:**

700

**4. Net Height [mm]:**

330

**5. Net Weight [kg]:**

36.00

**6. Gross Width [mm]:**

440

**7. Gross depth [mm]:**

800

**8. Gross Height [mm]:**

390

**9. Gross Weight [kg]:**

42.00

**10. Device type:**

Electric unit

**11. Construction type of device:**

Table top

**12. Power electric [kW]:**

4.500

**13. Loading:**

400 V / 3N - 50 Hz

**14. Protection of controls:**

IPX4

**15. Material:**

AISI 304 top plate, AISI 430 cladding

**16. Indicators:**

operation and warm-up

**17. Worktop material:**

Chrome plated steel

**18. Worktop Thickness [mm]:**

1.20

**19. Surface finish:**

polished chrome 0.03 mm

**20. Maximum device temperature [°C]:**

300

**21. Minimum device temperature [°C]:**

50

**22. Service accessibility:**

Trough the frontal panel

**23. Safety thermostat:**

Yes

**24. Adjustable feet:**

Yes

**25. Griddle dimensions [mm x mm]:**

400 x 510

**26. Griddle thickness [mm]:**

12.00

**27. Container for liquid fat:**

Yes

**28. Removable rim:**

Yes

# Technical data sheet



Technical parameters

Fry-top griddle plate 40x51 electric chromed smooth without cabinet 400 V

Model

SAP Code

00012427

## 29. Top type:

Smooth